

Januar 2010

January 2010

DE20080314



**Anleitung: Sportkotflügel SCR RIM
BMW F800R**

Lieferumfang:

- 1 x Kotflügel
- 1 x Kotflügelstrebe links
- 1 x Kotflügelstrebe rechts
- 1 x Gabelstabilisator
- 4 x Linsenkopfschraube M8x20 A2
- 4 x Linsenflanschschraube M5x20 A2
- 4 x Distanz 3mm POM
- 4 x U-Scheibe M5 groß A2
- 4 x Mutter selbstsichernd M5 A2
- 1 x Zellgummistreifen 10x5mm 50mm
- 4 x U-Scheibe M6 klein A2
- 4 x Linsenkopfschraube M6x16 A2
- 4 x Distanz 2mm V2A

Achtung! Wichtige Hinweise

Alle Schraubverbindungen nach 50Km kontrollieren und nachziehen!

Achtung! Wenn Sie zusätzlich Original-Zubehör oder Zubehör anderer Hersteller montieren, sind alle Teile auf Freigängigkeit, Kollision und Passform zu prüfen!

**Anziehmoment für M6 max. 9,7Nm!
Anziehmoment für M8 max. 20Nm!**

Um potentielle Berührungspunkte zu eliminieren, den beigelegten Zellgummistreifen zuschneiden und an den entsprechenden Punkten aufkleben!

**Instruction: Sport mudguard SCR RIM
BMW F800R**

Contents:

- 1 x mudguard
- 1 x mudguard strut left
- 1 x mudguard strut right
- 1 x fork stabiliser bar
- 4 x button head screw M8x20 A2*
- 4 x socket flange button head screw M5x20 A2*
- 4 x spacer 3mm POM
- 4 x washer M5 large A2*
- 4 x self securing nut M5 A2*
- 1 x foam rubber stripe 10x5mm 50mm
- 4 x washer M6 small A2*
- 4 x button head screw M6x16 A2*
- 4 x spacer 2mm stainless steel

*A2 = stainless steel

Attention: important tips, explanations

Check all screws after 50Km and retighten if necessary!

When fitting with additional accessories, original or third-party, ensure a precise fit and check for possible interference!

**Maximum Torque M6 9,7Nm!
Maximum Torque M8 20Nm!**

To avoid parts from touching and wearing, cut the rubber strips to size and stick them between surfaces close to one another!

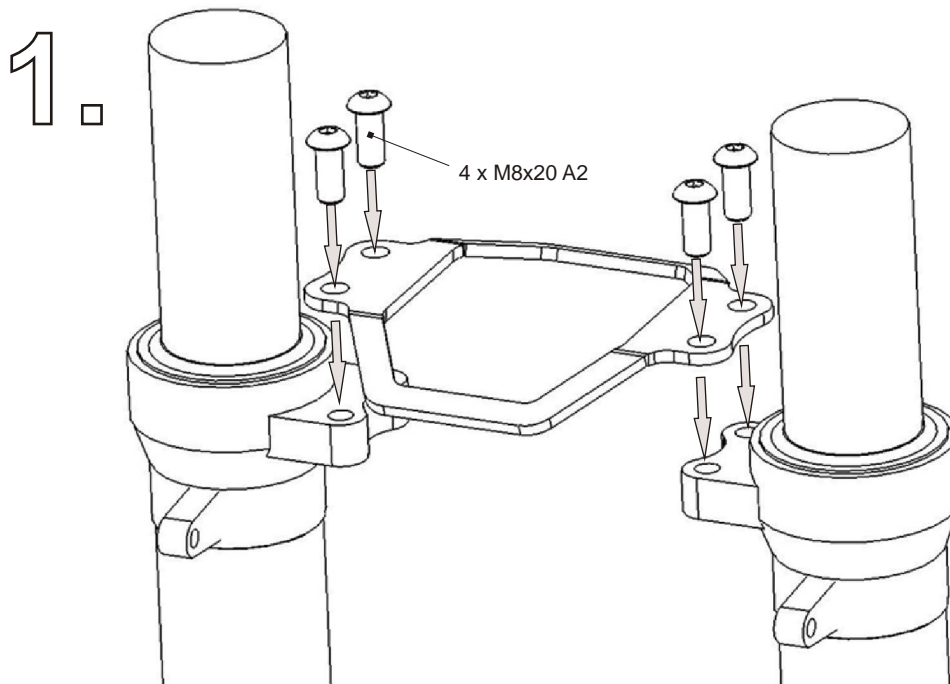

DE20080314

Januar 2010

January 2010

2.

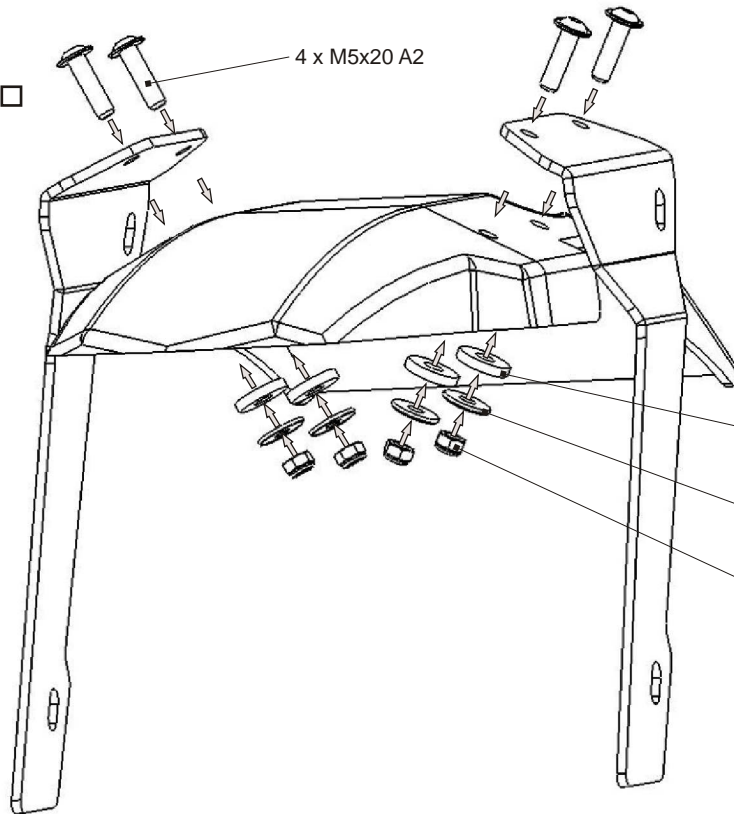

4 x M5x20 A2

4 x Distanz 3mm POM
4 x spacer 3mm POM

4 x U-Scheibe M5 groß A2
4 x washer M5 large A2

4 x Mutter selbstsichernd M5 A2
4 x self securing nut M5 A2

3.

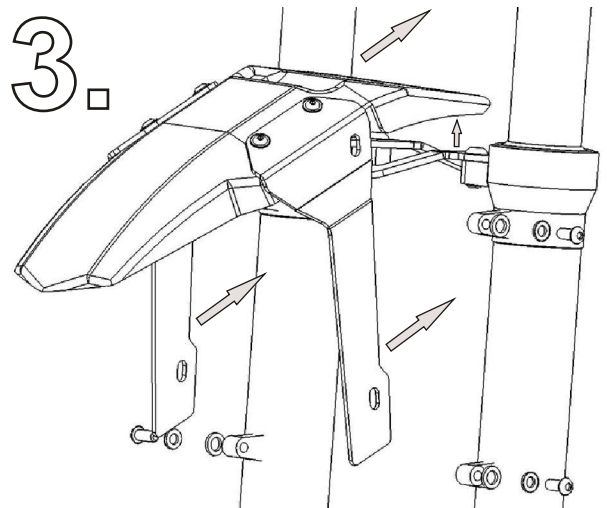

4.

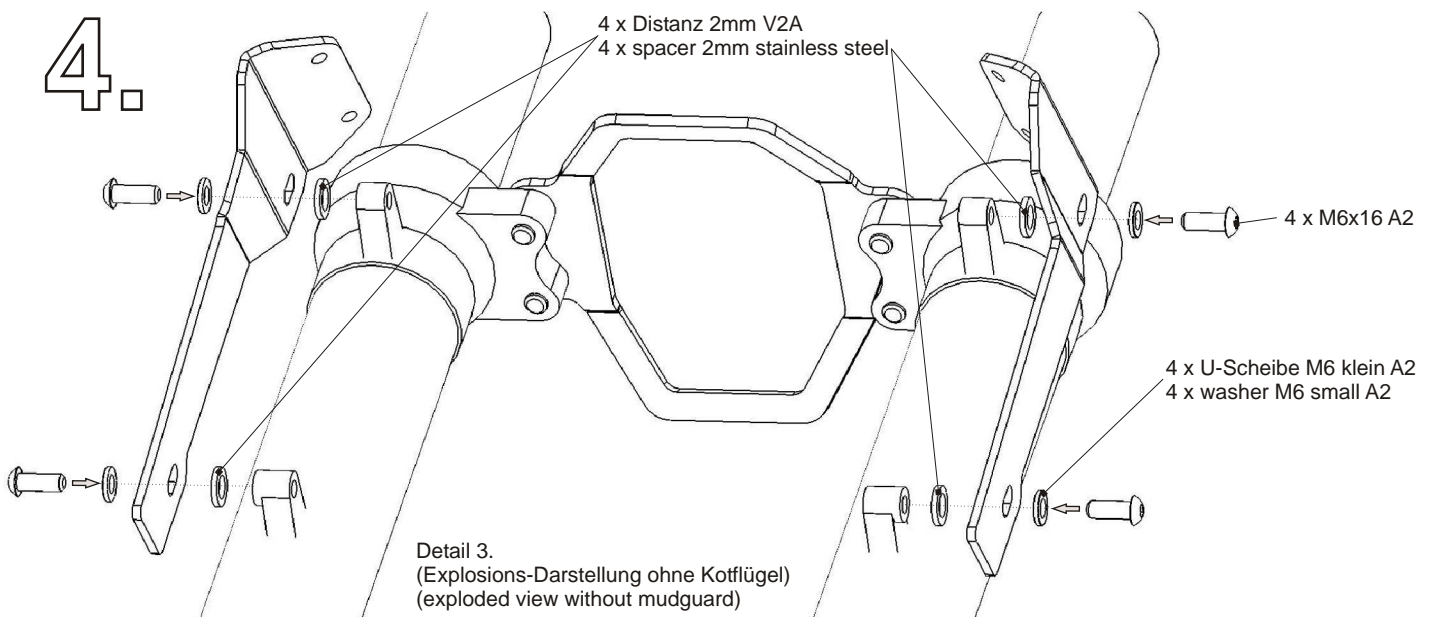

4 x Distanz 2mm V2A
4 x spacer 2mm stainless steel

4 x M6x16 A2

4 x U-Scheibe M6 klein A2
4 x washer M6 small A2

Detail 3.
(Explosions-Darstellung ohne Kotflügel)
(exploded view without mudguard)